



Commercial Concrete/ Masonry Database

The Precision Commercial Concrete Masonry Database gives you the information you need to begin estimating productively right away. Thousands of standard industry items—from spread footings and tilt up walls to brick and stone components—are included to get you started. Just add your own pricing and you're ready to go.

You can also customize the database to fit your unique needs. Precision makes it easy to add your own items, formulas, assemblies, productivity and conversion factors to the database as you estimate.

The database also includes Smart Assemblies™ that let you take off even the most complicated building component, like a concrete beam, in one step. For example, when taking off a rectangular concrete beam, simply enter one set of dimensions and the assembly will generate labor and material costs for the formwork, concrete, snap ties and more.

General Database Specifications

- More than 1500 Items
- More than 500 Formulas
- 84 Smart Assemblies
- 31 Bill of Materials Classes

Division	Number of Assemblies
General Conditions	1
Concrete Foundations	14
Concrete Walls	9
Concrete Columns	2
Concrete Beams	1
Concrete Slabs on Grade	13
Concrete Suspended Slabs	6
Concrete Topping	2
Concrete Misc.	6
Masonry Brick	8
Masonry Concrete Block	7
Masonry Glazed Block	1
Masonry Stone Work	1

The Concrete Masonry database documentation outlines the construction logic used in setting up each of Timberline's Smart Assemblies™...

Commercial Concrete/Masonry Database

File Edit Bookmark Options Help

Help Topics Print

0350 Beams - Rectangular

Assumptions Items Variables Drawing

Assumptions

This assembly takes off all concrete and forming required for concrete beams. It does not include the shoring and reshoring necessary for the beam. This must be taken off separately.

- Beam concrete strengths included are 2,000 psi through 7,000 psi.
- Forms are assumed to be made from half inch plywood.
- Rub finish and chamfer strip are also available.
- Snapties are available, and, if you answer yes to include snapties, you will be prompted to enter the snaptie spacing and the number of ties in a snaptie group for the depth of the beam entered. The assembly will then calculate the number of groups required based upon the length and the spacing and multiply that amount by the ties per beam depth. It will then select the proper length snaptie based on the width of the beam. Beam widths can go to 36 inches wide. Odd sized snapties are rounded up to the next largest tie.

Items

Phase	Item	Description	Unit
		Concrete Beams	
		Formula: CY Conc Beam	
3138.00	10	Beam Bottom Form	
		Formula: SF Beam Bottoms	
3138.00	20	Beam Sides - 1/2" Plywood	
		Formula: SF Beam sides	
3159.00	60	Strip/Oil Forms-All other	
		Formula: SF Conc Beam Forms	
3380.01	220	Rub, Cut, & Patch	
		Formula: SF Conc Beam Forms	
3380.01	230	Rub Finish	
		Formula: wSF Rub finish Beam	
3161.00	10	Chamfer Strip (3/4")	
		Formula: Length * # Runs of Chamfer	
		Snapties Conc Beam	

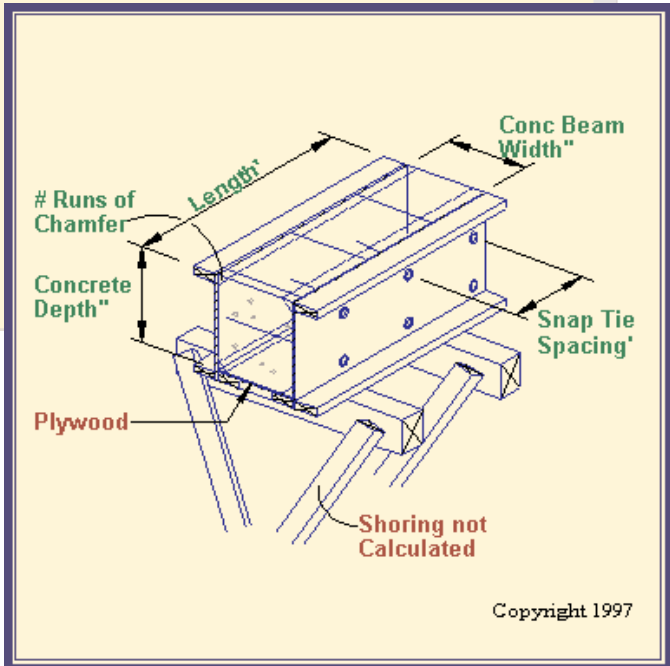

...and includes a drawing that lets you see its associated variables.

Your Timberline Solution Provider:

Software that fits your business™



TIMBERLINE and the Timberline logo as it appears in this document are registered Marks, "Software that fits your business" and Smart Assemblies are trademarks, and Precision Collection is a registered trademark of Timberline Software Corporation. All other trademarks or registered trademarks are the property of their respective holders.

Timberline Software Corporation
 800.628.6583 • Fax 503.439.5010 • www.timberline.com